

# Grounding Solutions

Said Shalabi

# Topics

- Types of Grounding Systems
- Associated Benefits & Disadvantages
- Transitioning to Resistance Grounding
- Sizing of Neutral Grounding Resistors
- LRG vs HRG
- Pulsing
- SMART HRG

Ungrounded

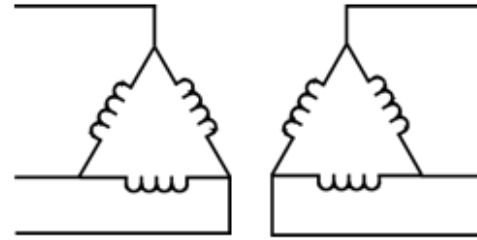

Solidly Grounded

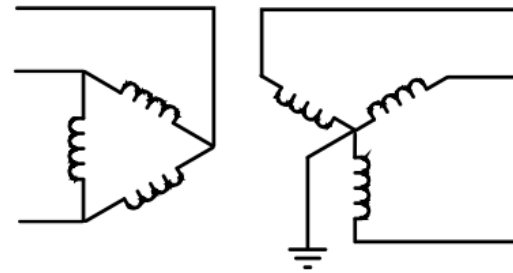

Resistively Grounded

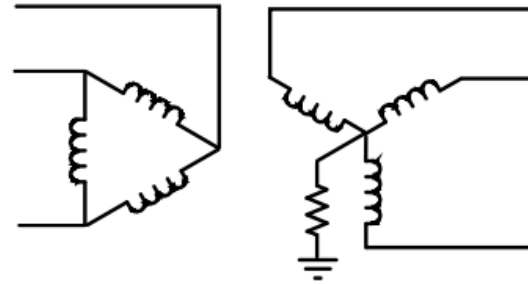

# Ungrounded Systems

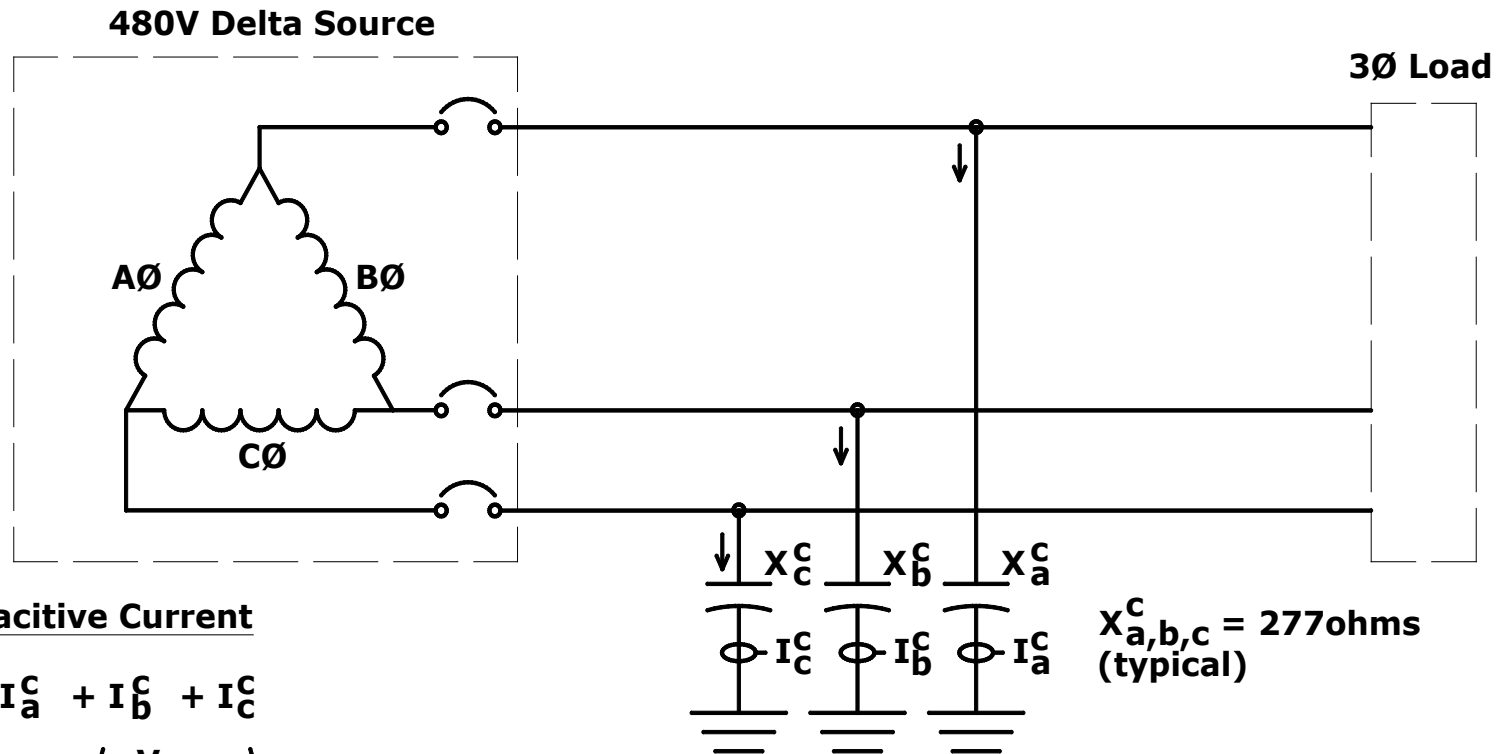

**Total Capacitive Current**

$$0 = I_a^c + I_b^c + I_c^c$$

$$I_{a,b,c}^c = \left( \frac{V_{l-n}}{X_{a,b,c}^c} \right) [120^\circ \text{ apart}]$$

# Ungrounded Systems...

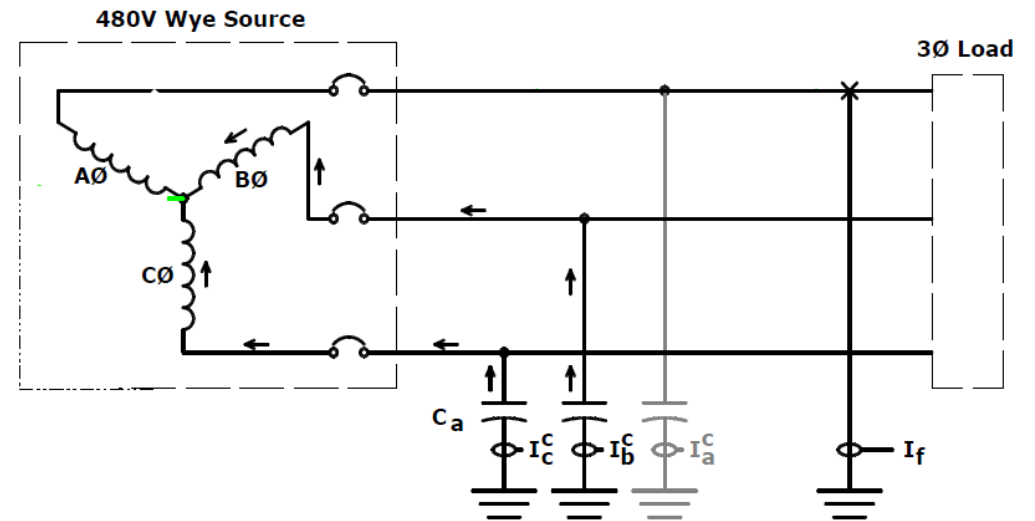
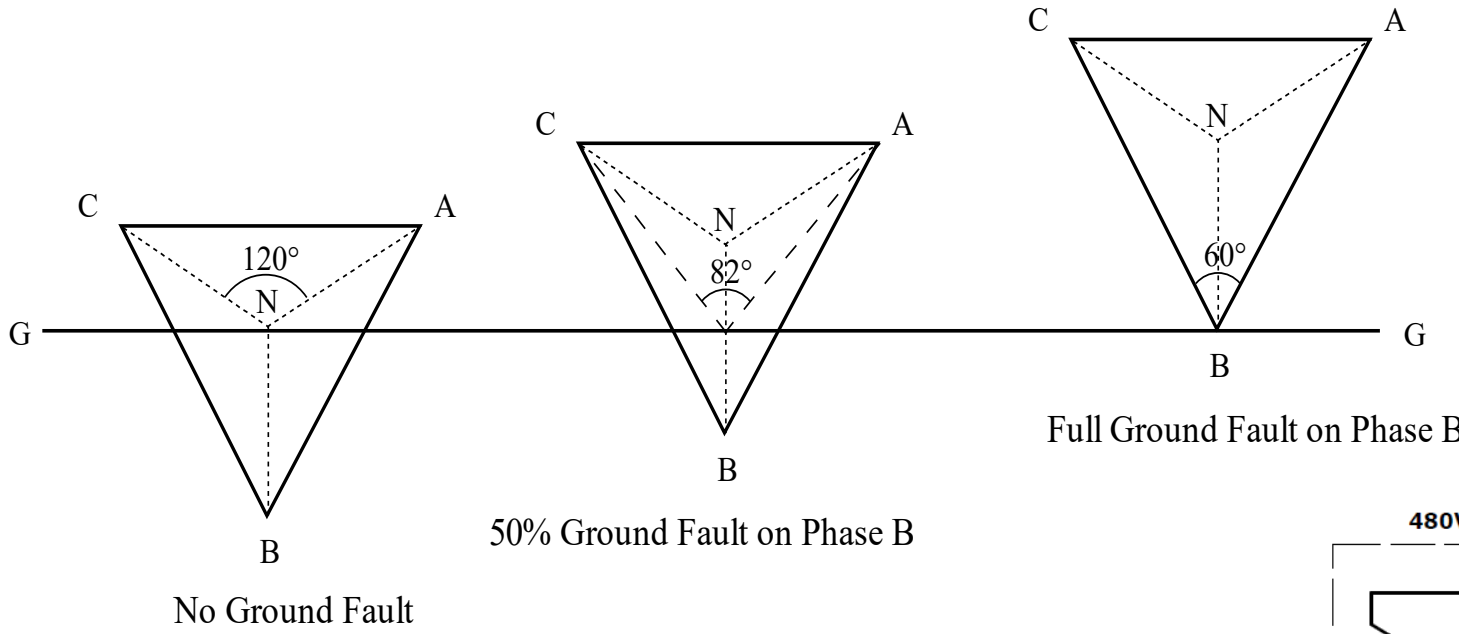

# Ungrounded Systems...

- Negligible fault current and no tripping on the first ground fault
- Difficulty to identify the location of the fault
- In the event of a second ground fault, an unplanned outage will occur
- Susceptible to over-voltages during intermittent or arcing ground faults\*

# Ungrounded Systems...

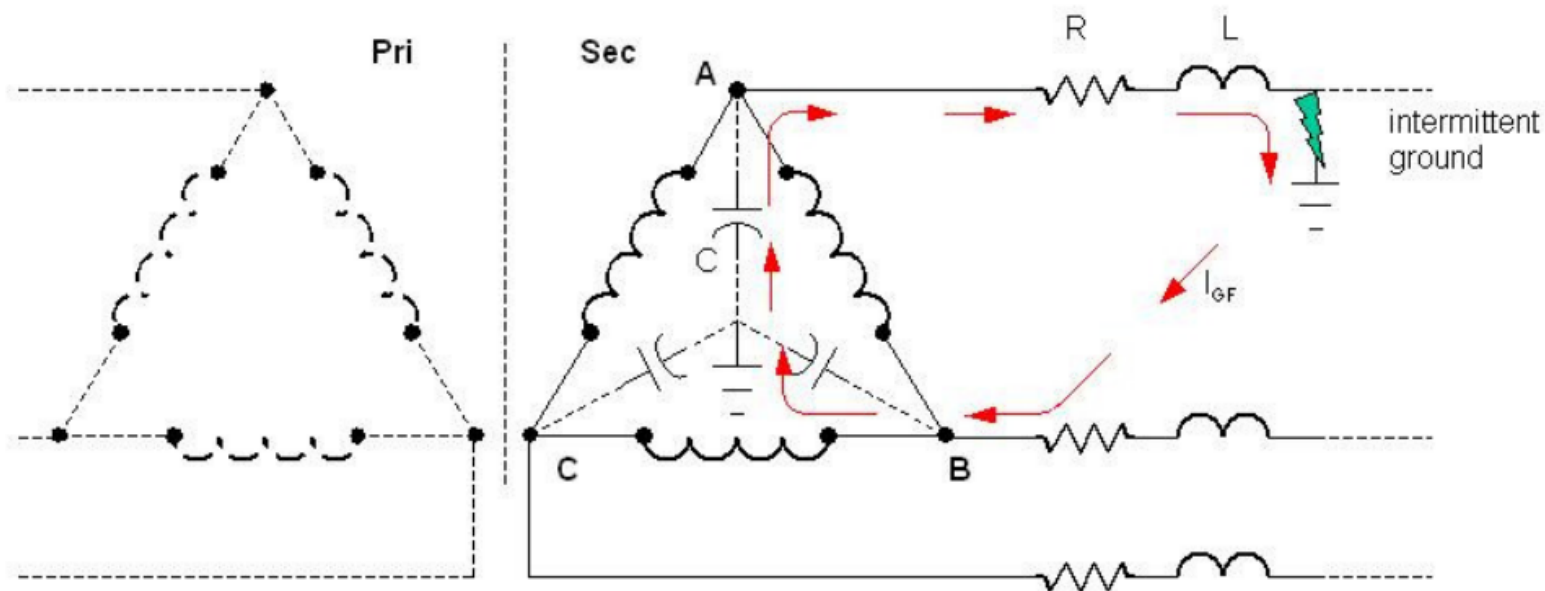

- Current through phase-to-ground capacitance leads phase to ground voltage by 90 degrees.
  - Current must flow to the two plates of the capacitor, where charge is stored. Only after the charge accumulates at the plates of a capacitor is a voltage difference established.

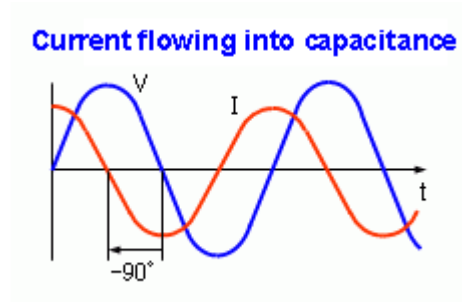
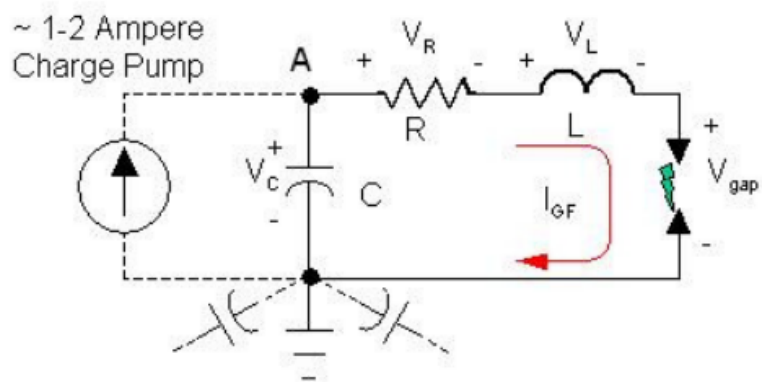

# Ungrounded Systems...

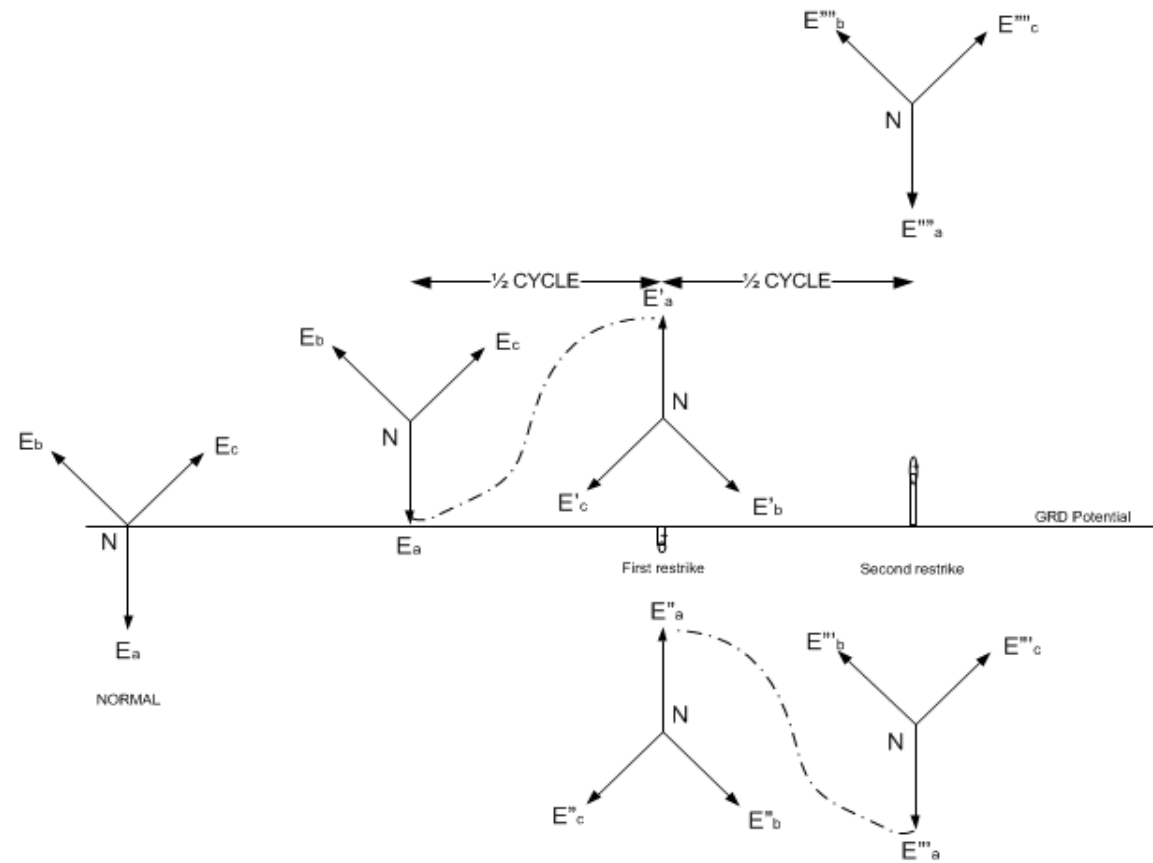



# Ungrounded Systems...

- Reliability
  - Prone to double faults and thus trip outs
- Safety
  - Transient over-voltages can occur
- Cost Effectiveness
  - Locating faults is difficult
- Scheduled Maintenance
  - Double faults can cause unscheduled shut downs
  - Coordination lost in the case of a second ground fault

# Solidly Grounded Systems

- Eliminates transient over-voltage problem associated with ungrounded systems
- Permits line-to-neutral loads when the neutral is distributed
- Faulted path allows for the ability to locate the fault, but cause unscheduled service interruption
- Susceptible to arcing ground faults\*

# National Electrical Code

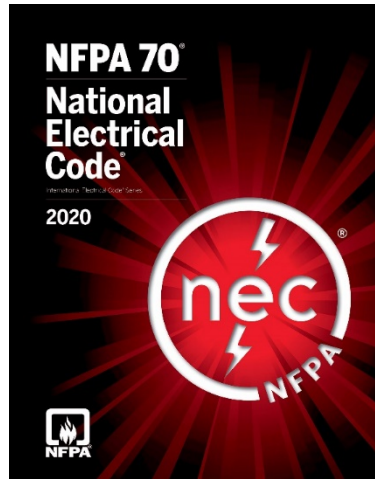

2020 NFPA 70

**230.95 Ground-Fault Protection of Equipment.** Ground-fault protection of equipment shall be provided for solidly grounded wye electric services of more than 150 volts to ground but not exceeding 1000 volts phase-to-phase for each service disconnect rated 1000 amperes or more. The grounded conductor for the solidly grounded wye system shall be connected directly to ground through a grounding electrode system, as specified in 250.50, without inserting any resistor or impedance device.

The rating of the service disconnect shall be considered to be the rating of the largest fuse that can be installed or the highest continuous current trip setting for which the actual overcurrent device installed in a circuit breaker is rated or can be adjusted.

**(A) Setting.** The ground-fault protection system shall operate to cause the service disconnect to open all ungrounded conductors of the faulted circuit. The maximum setting of the ground-fault protection shall be 1200 amperes, and the maximum time delay shall be one second for ground-fault currents equal to or greater than 3000 amperes.

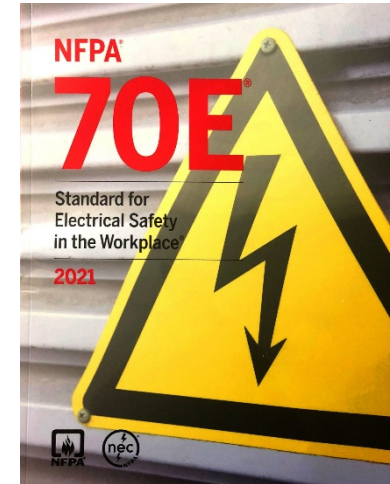

2021 NFPA 70E

# Canadian Electrical Code

**14-102 Ground fault protection (see Appendix B)**

- 1) Ground fault protection shall be provided to de-energize all normally ungrounded conductors of a faulted circuit that are downstream from the point or points marked with an asterisk in Diagram 3 in the event of a ground fault in those conductors as follows:
  - a) for circuits of solidly grounded systems rated more than 150 volts-to-ground, less than 750 V phase-to-phase, and 1000 A or more; and
  - b) for circuits of solidly grounded systems rated 150 V or less to ground and 2000 A or more.
- 2) Except as permitted by Subrule 8), the maximum setting of the ground fault protection shall be 1200 A and the maximum time delay shall be 1 s for ground fault currents equal to or greater than 3000 A.
- 3) The ampere rating of the circuits referred to in Subrule 1) shall be considered to be
  - a) the rating of the largest fuse that can be installed in a fusible disconnecting device;
  - b) the highest trip setting for which the actual overcurrent device installed in a circuit breaker is rated or can be adjusted; or
  - c) the ampacity of the main conductor feeding the devices located at points marked with an asterisk in Item 2 of Diagram 3, in the case where no main disconnecting device is provided.
- 4) This protection shall be provided by
  - a) an overcurrent device that incorporates ground fault protection;
  - b) a ground fault tripping system consisting of a sensor(s), relay, and auxiliary tripping mechanism; or
  - c) other means.
- 5) The sensor(s) referred to in Subrule 4) shall be
  - a) sensors that vectorially totalize the currents in all conductors of the circuit, including the grounded circuit conductor, where one is provided, but excluding any current flowing in the ground fault return current path;
  - b) sensors that sense ground fault current flowing from the fault to the supply end of the system through the ground return path; or
  - c) a combination of these two types of sensors.
- 6) Sensors referred to in Subrule 5) a) shall be permitted to be installed at any point between the supply transformer and the downstream side of the disconnecting means marked with an asterisk in Diagram 3, but if located downstream from this disconnecting means, the sensors shall be placed as close as practicable to its load terminals.
- 7) Sensors referred to in Subrule 5) b) shall be located on each connection between neutral and ground; however, where the neutral is grounded both at the supply transformer and at the

switching centre, the sensor at the transformer shall not be required, provided that the maximum pickup setting of the ground fault relay does not exceed 1000 A.

- 8) In ground fault schemes where two or more protective devices in series are used for ground fault coordination, the upstream protective device settings shall be permitted to exceed those specified in Subrule 2) where necessary to obtain the desired coordination, provided that the final downstream ground fault protective device in each circuit required to be protected conforms to the requirements of Subrule 2).

# Solidly Grounded Systems...

- “...and the maximum time delay shall be one (1) second”
  - Equates to 60 cycles (60Hz)
  - Refer to IEEE 1584, *Guide for Performing Arc Flash Calculations...*
    - Parameters: 208V to 15kV; three-phase; 50 or 60Hz; 700A to 106kA; 13mm to 152 mm conductor gaps
- Danger from arcing ground faults, where the fault current may be less than half of the short circuit current level (due to voltage drop)
  - This may be an issue for the “I” function of corresponding LSIG breakers
- How do you reduce the incident energy levels during an arcing fault?

$$E_{600} = \frac{12.552}{50} T \times 10^6 \left( k1 + k2 \lg G + \frac{k3 I_{sc,600}}{k4 I_{bf}^2 + k5 I_{bf}^6 + k6 I_{bf}^5 + k7 I_{bf}^4 + k8 I_{bf}^3 + k9 I_{bf}^2 + k10 I_{bf}} + k11 \lg I_{bf} + k12 \lg D + k13 \lg I_{sc,600} + \lg \frac{1}{CF} \right)$$

# National Electrical Code

## 517.17 Ground-Fault Protection.

**(A) Applicability.** The requirements of 517.17 shall apply to hospitals, and other buildings (including multiple-occupancy buildings) with critical care (Category 1) spaces or utilizing electrical life-support equipment, and buildings that provide the required essential utilities or services for the operation of critical care (Category 1) spaces or electrical life-support equipment.

**(B) Feeders.** Where ground-fault protection is provided for operation of the service disconnecting means or feeder disconnecting means as specified by 230.95 or 215.10, an additional step of ground-fault protection shall be provided in all next level feeder disconnecting means downstream toward the load. Such protection shall consist of overcurrent devices and current transformers or other equivalent protective equipment that shall cause the feeder disconnecting means to open.

The additional levels of ground-fault protection shall not be installed on the load side of an essential electrical system transfer switch.

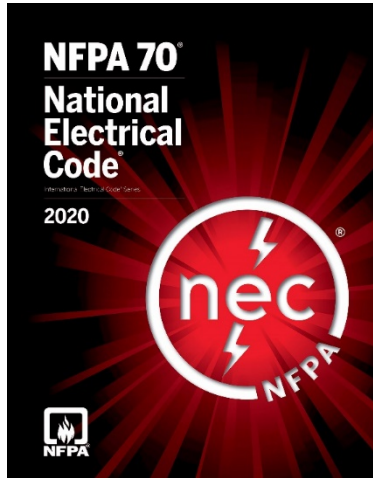

2020 NFPA 70

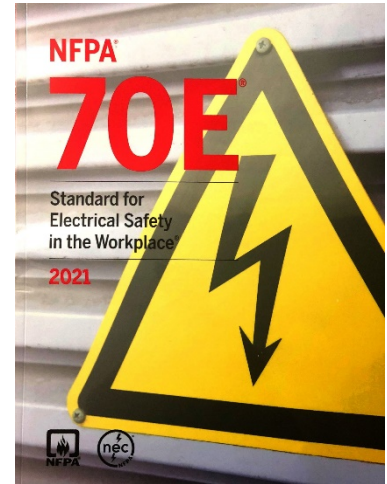

2021 NFPA 70E

# Canadian Electrical Code

## 14-102 Ground fault protection (see Appendix B)

- 1) Ground fault protection shall be provided to de-energize all normally ungrounded conductors of a faulted circuit that are downstream from the point or points marked with an asterisk in Diagram 3 in the event of a ground fault in those conductors as follows:
  - a) for circuits of solidly grounded systems rated more than 150 volts-to-ground, less than 750 V phase-to-phase, and 1000 A or more; and
  - b) for circuits of solidly grounded systems rated 150 V or less to ground and 2000 A or more.
- 2) Except as permitted by Subrule 8), the maximum setting of the ground fault protection shall be 1200 A and the maximum time delay shall be 1 s for ground fault currents equal to or greater than 3000 A.
- 3) The ampere rating of the circuits referred to in Subrule 1) shall be considered to be
  - a) the rating of the largest fuse that can be installed in a fusible disconnecting device;
  - b) the highest trip setting for which the actual overcurrent device installed in a circuit breaker is rated or can be adjusted; or
  - c) the ampacity of the main conductor feeding the devices located at points marked with an asterisk in Item 2 of Diagram 3, in the case where no main disconnecting device is provided.
- 4) This protection shall be provided by
  - a) an overcurrent device that incorporates ground fault protection;
  - b) a ground fault tripping system consisting of a sensor(s), relay, and auxiliary tripping mechanism; or
  - c) other means.
- 5) The sensor(s) referred to in Subrule 4) shall be
  - a) sensors that vectorially totalize the currents in all conductors of the circuit, including the grounded circuit conductor, where one is provided, but excluding any current flowing in the ground fault return current path;
  - b) sensors that sense ground fault current flowing from the fault to the supply end of the system through the ground return path; or
  - c) a combination of these two types of sensors.
- 6) Sensors referred to in Subrule 5) a) shall be permitted to be installed at any point between the supply transformer and the downstream side of the disconnecting means marked with an asterisk in Diagram 3, but if located downstream from this disconnecting means, the sensors shall be placed as close as practicable to its load terminals.
- 7) Sensors referred to in Subrule 5) b) shall be located on each connection between neutral and ground; however, where the neutral is grounded both at the supply transformer and at the

switching centre, the sensor at the transformer shall not be required, provided that the maximum pickup setting of the ground fault relay does not exceed 1000 A.

- 8) In ground fault schemes where two or more protective devices in series are used for ground fault coordination, the upstream protective device settings shall be permitted to exceed those specified in Subrule 2) where necessary to obtain the desired coordination, provided that the final downstream ground fault protective device in each circuit required to be protected conforms to the requirements of Subrule 2).

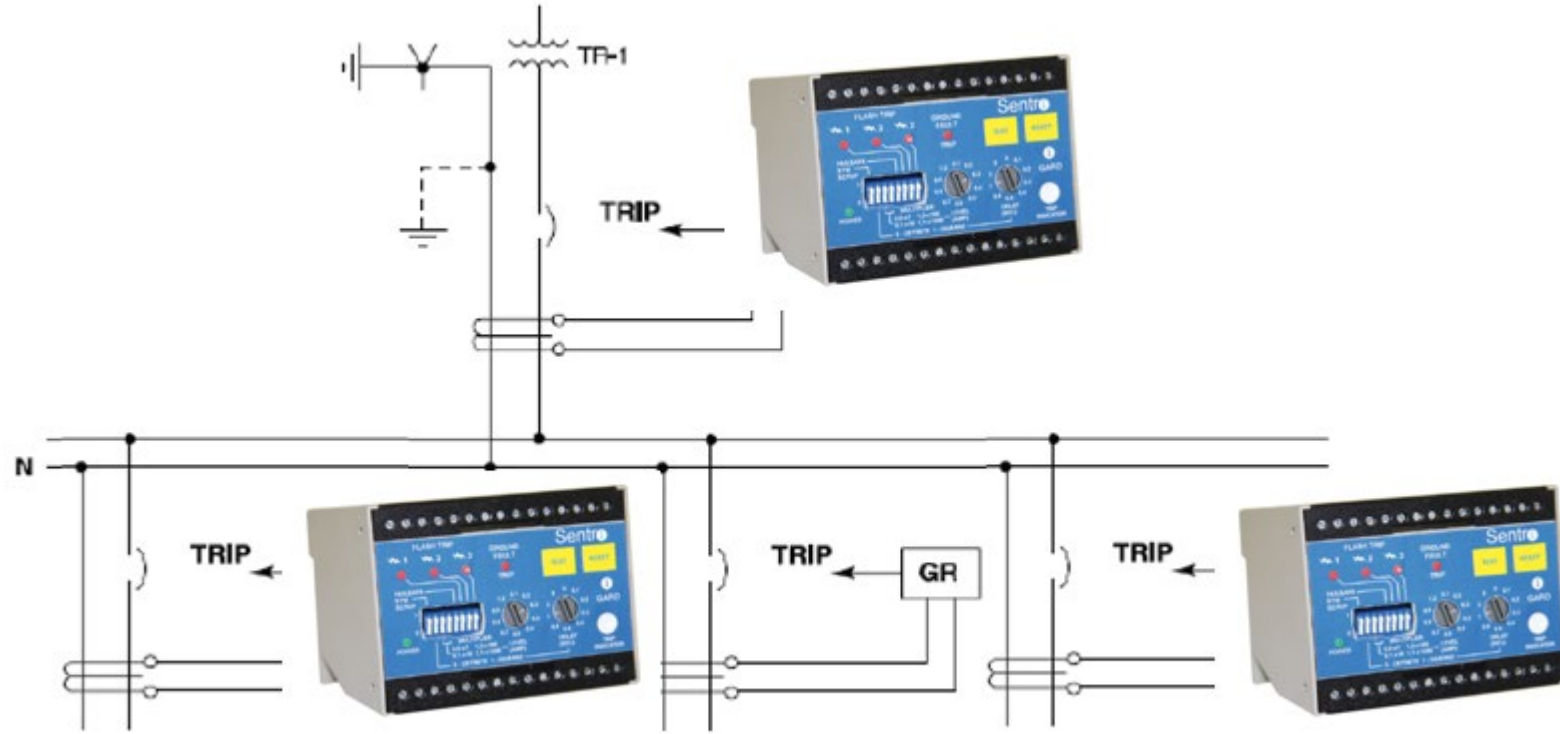

Zone Selective Instantaneous Protection



# Resistively Grounded Systems

- Typically used in LV (480/600V) and MV systems to limit ground fault current
- No arcing ground faults as with solidly grounded systems\*
- No over-voltages as with ungrounded systems
- Applications started with process industries, wastewater, hospitals, and data centers
- Now, practically used everywhere when 3 phase, 3 wire distribution is used



**NGR**

NEUTRAL GROUNDING RESISTOR

# Resistively Grounded Systems

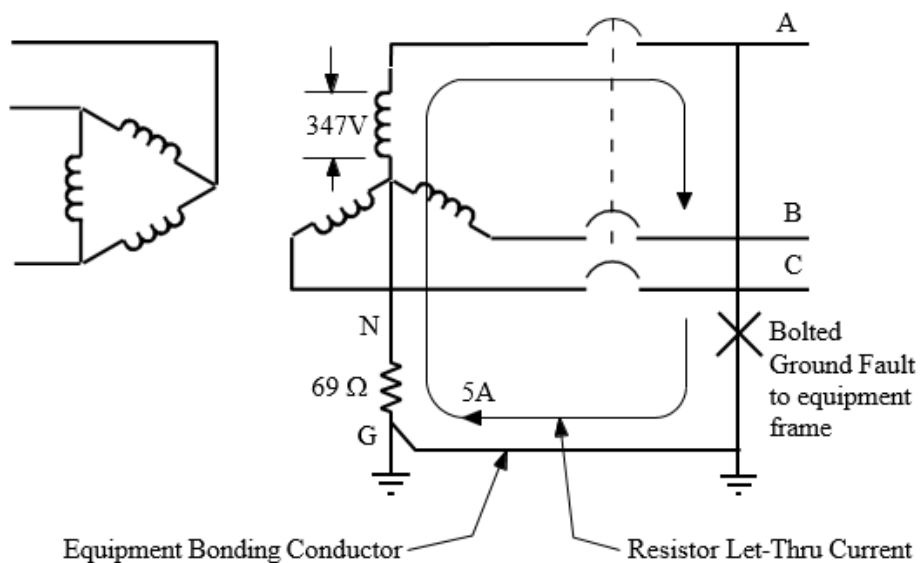

**NGR**  
NEUTRAL GROUNDING RESISTOR

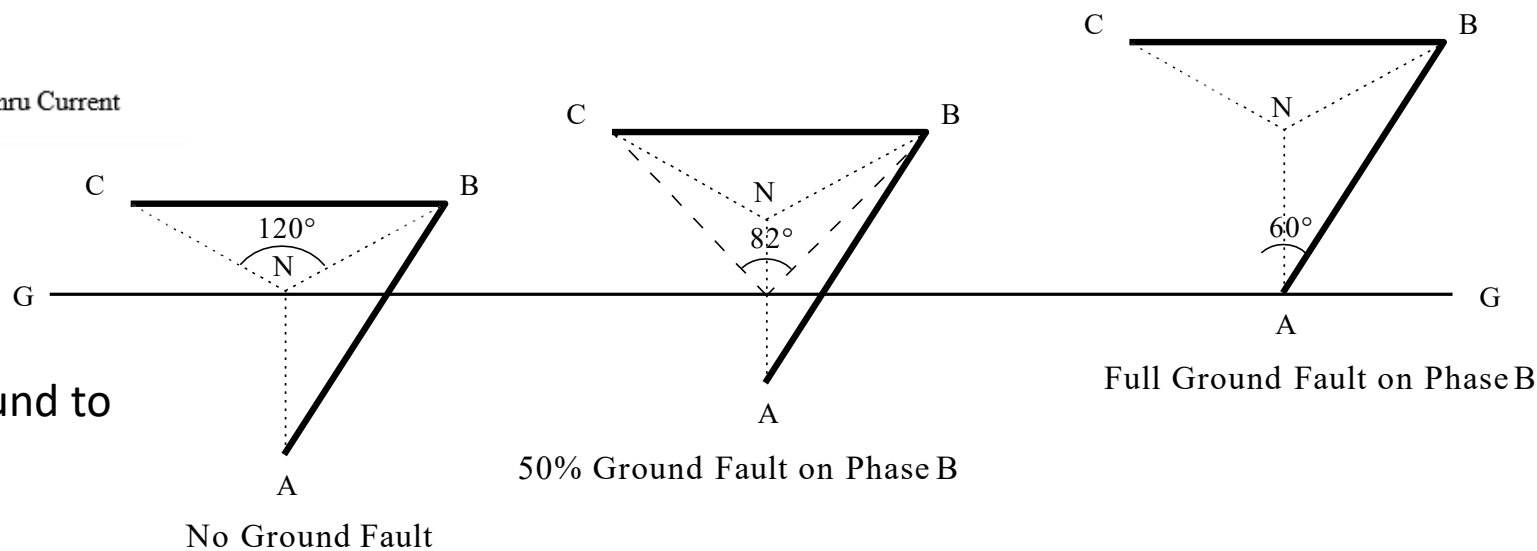

- Resistor inserted between neutral and ground to limit ground fault current

# Transitioning to Resistance Grounding

- Cabling must be rated for the L-L voltage of the system
- Lightning/Surge arrestors must be rated for the L-L voltage of the system
- VFDs, SPDs, and UPS should be compatible with the HRG application
- Single phase loads should be isolated using an isolation transformer

Voltage		Insulation
< 5000		100 %
>5000	Ground fault on system < 1 min.	100 %
	1 min < t < 1 hour	133 %
	t > 1 hour	173%

NEC 2020, 311.10 – Conductors and Cabling

# Sizing the NGR

- Rated Voltage
- Rated Current
- Rated Time
- Maximum Temperature
- Temperature Coefficient of Resistance

# Sizing the NGR

- Rated Voltage
  - The resistor shall be rated for constant voltage, where the rated voltage is equal to the line-to-neutral voltage of the system ( $V_{L-N} = V_{L-L}/\sqrt{3}$ )
- Rated Current
  - The current seen during a maximum (100%) single phase ground fault condition, and is dependent on the impedance of the neutral grounding resistor ( $I = V/R$ )
  - **The specified rated let-through current of the NGR must be greater than the total capacitive charging current of the system**

# Sizing the NGR

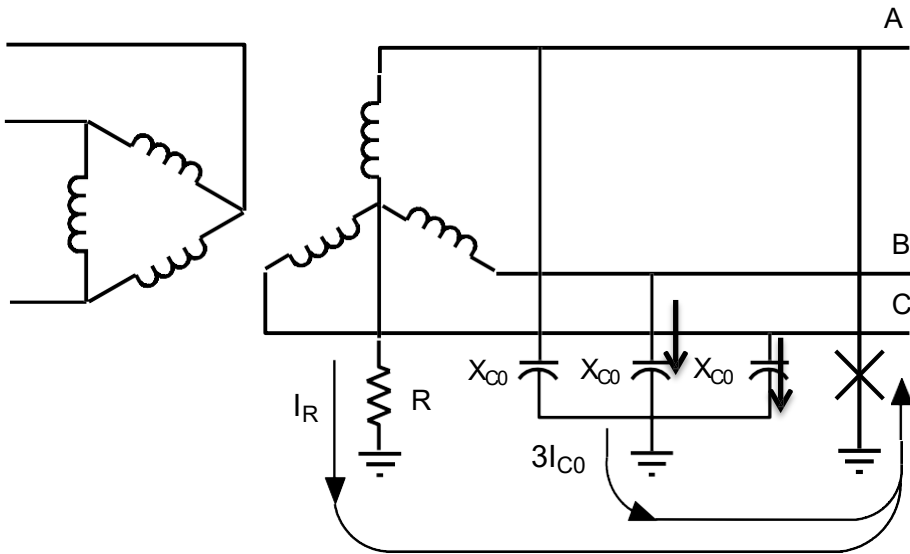

- $C_o$  is the distributed capacitance of the insulation in each phase to ground
- $X_{co}$  is the reactance created for each phase to ground
- $I_{co}$  is the generated charging current **per phase**
  - $I_{co} = V_{L-N} / X_{co}$
- When a L-G fault occurs on a single phase, the two un-faulted phases rise by  $\sqrt{3}$  to  $V_{L-L}$ , and the phase to ground current becomes  $\sqrt{3} * I_{co}$

$$I_F = \sqrt{(I_R)^2 + (3I_{C0})^2}$$

**$I_R$  should overcome the  $3I_{C0}$**   
Contributed by net capacitance to ground

$$I_{F_{MIN}} = \sqrt{2} (3I_{C0})$$

At minimum fault current,  $I_R = 3I_{C0}$

# Sizing the NGR

- Rated Time
  - The rated duty cycle of the NGR shall be 10 seconds, 1 minute, 10 minutes, or continuous (steady-state)

Table 25—Limiting temperature rises above 30 °C ambient for current carrying parts of neutral grounding resistors

		Temperature rise (°C) <sup>a</sup>
<i>Steady State</i> for continuous current ratings	Steady state (hot-spot)	385
<i>Rated Time</i> for thermal current ratings less than Steady-State	Extended-time (hot-spot) (average)	610
	Ten-minute (hot-spot) (average)	610
	Less than 10 min (hot-spot) (average)	760

<sup>a</sup> The temperature rise tests shall be performed according to the time rating of the resistor.

# Sizing the NGR

- Temperature Coefficient of Resistance

$$\alpha = \frac{R_2 - R_1}{R_1(\theta_2 - \theta_1)} \quad R_2 = R_1 [1 + \alpha(\theta_2 - \theta_1)]$$

- Where;
  - $R_1$  is the initial resistance( $\Omega$ )
  - $R_2$  is the final resistance( $\Omega$ )
  - $T_1$  is the Initial Temperature ( $^{\circ}\text{C}$ )
  - $T_2$  is the final Temperature( $^{\circ}\text{C}$ )
  - $\alpha$  is the Temperature coefficient of resistance( $1/ ^{\circ}\text{C}$ )



# Sizing the NGR

- Example:
  - NGR with the following parameters:
    - Rated Voltage = 2400V
    - Rated Current = 400A
    - Rated Time = 10S
    - Maximum Temperature Rise = 760°C
    - Temperature Coefficient of Resistance =

Alloy	Temperature Coefficient of Resistance (1/°C) $\alpha$	Percent change in Resistance	Current decrease as a percentage
AISI 304	0.00092	70% Increase to 10.2 $\Omega$	41.1% to 235 A
AISI 430	0.00146	110 % Increase to 12.65 $\Omega$	52.5% to 189 A
18SR	0.000358	27 % Increase to 7.63 $\Omega$	21% to 314 A
1JR	0.000241	18 % Increase to 7.1 $\Omega$	15.4 % to 338 A

# National Electrical Code

**250.36 High-Impedance Grounded Neutral Systems.** High-impedance grounded neutral systems in which a grounding impedance, usually a resistor, limits the ground-fault current to a low value shall be permitted for 3-phase ac systems of 480 volts to 1000 volts if all the following conditions are met:

- (1) The conditions of maintenance and supervision ensure that only qualified persons service the installation.
- (2) Ground detectors are installed on the system.
- (3) Line-to-neutral loads are not served.

ENHANCED CONTENT

Collapse X

The following exhibit shows the location of the grounding impedance device (in this example, a resistor) in a high-impedance grounded neutral system, which limits the amount of ground-fault current in the neutral conductor when a line-to-ground fault occurs.

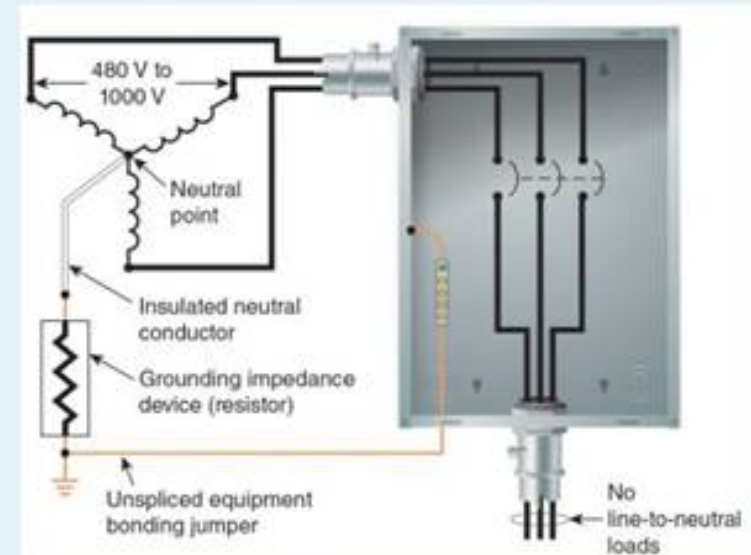

The grounding impedance is selected to limit fault current to a value that is slightly greater than or equal to the capacitive charging current. This system is used where continuity of power is required. Therefore, a ground fault results in an alarm condition rather than in the tripping of a circuit breaker. The alarm allows for the safe and orderly shutdown of a process for which a non-orderly shutdown could introduce additional or increased hazards.

For requirements for impedance grounded neutral systems rated over 1000 volts, see **250.187**.

# Canadian Electrical Code

## Impedance grounded systems

### 10-300 Qualified persons (see Appendix B)

Where an electrical system is connected to an impedance grounding device, the system shall be maintained by a qualified person.

### Δ 10-302 Use (see Appendix B)

- 1) Ungrounded conductors of an impedance grounded system shall be insulated to the nominal line-to-line voltage of the system.
- 2) The integrity of an impedance grounded system shall be monitored and controlled, as required by Table 17.
- 3) Alarms required by Table 17 shall
  - a) be clearly labelled as to their purpose;
  - b) clearly annunciate the status of the system to persons monitoring it; and
  - c) continue signalling until the condition is corrected.

Table 17 summarizes the following:

- Where a neutral grounding device is used on an electrical system operating at 5kV or less, provision shall be made to automatically de-energize the system on the detection of a ground fault, unless:
  - The ground fault current is controlled at 10A or less; and
  - A visual or audible alarm, or both, clearly indicate the presence of a ground fault is provided

Δ

**Table 17**  
**Impedance grounded systems — Conditions for initiation of automatic alarm and de-energization of the system**  
(See Rule 10-302.)

Impedance grounded system configuration	Conditions for initiation of automatic alarm and de-energization of system		
	Ground fault on current-carrying conductors	Ground fault on conductor from source to impedance grounding device	Loss of continuity from the source through the impedance grounding device to the grounded conductive parts of equipment
Line-to-neutral loads are served (4-wire), all voltages/currents	Alarm and de-energize system immediately	Alarm and de-energize system immediately	Alarm and de-energize system immediately
Line-to-neutral loads are not served (3-wire) System is <ul style="list-style-type: none"> <li>• 5 kV or less; and</li> <li>• ground fault is limited to 10 A or less</li> </ul>	Scenario 1 [see Note a)]	Alarm and de-energize system within the time rating of the impedance grounding device	Alarm
	Scenario 2 [see Note b)]	Alarm and de-energize system within the time rating of the impedance grounding device	Alarm and de-energize system within 48 h
Line-to-neutral loads are not served (3-wire) System is <ul style="list-style-type: none"> <li>• greater than 5 kV; or</li> <li>• ground fault is greater than 10 A</li> </ul>	Scenario 1 [see Note a)]	Alarm and de-energize system within the lesser of 48 h or the time rating of the impedance grounding device	Alarm
	Scenario 2 [see Note b)]	Alarm and de-energize system within the lesser of 48 h or the time rating of the impedance grounding device	Alarm and de-energize system within 48 h

**Note:** On the occurrence of a loss of continuity of the impedance grounding circuit from the system source through the impedance grounding device to the grounded non-current-carrying conductive parts of the electrical system, the device monitoring the system can operate in one of two ways:

- a) it can continue to detect a ground fault on an ungrounded system; or
- b) it can no longer detect a ground fault on an ungrounded system.

# Resistor Monitoring

- NGR Monitoring & Ground Fault Relay
  - Detects Open/Short Circuit Conditions

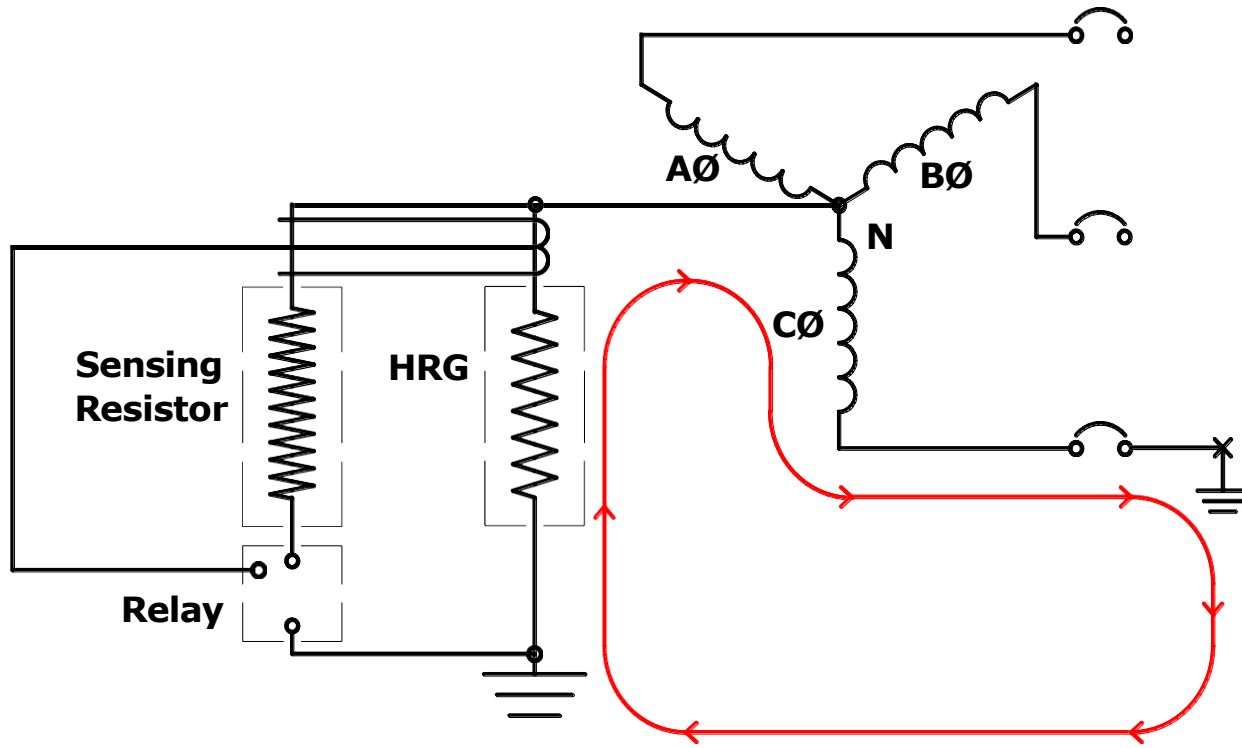

Loss of Ground in HRG Systems

# Sizing the NGR...

- High Resistance Grounding, HRG
  - $10A \geq I_R > 3I_{CO}$
  - Ability to alarm on GF and maintain operation, continuous duty resistor used
- Low Resistance Grounding, LRG
  - $I_R > 3I_{CO} > 10A$
  - Trip on GF required, short-time resistor used

# Low Resistance Grounding

- If System Charging Current,  $3I_{co} > 10A$ , rule out HRG
- Next step is to determine the minimum pickup for ground fault detection on the existing protection scheme
- Identify an acceptable let-through current greater than the minimum pickup (3-5x) to ensure that limited current is still able to trip the corresponding devices

# High Resistance Grounding

- When  $I_R \leq 10A$ ,
  - If Rated Voltage  $< 5kV$ :
    - Arc Flash Mitigation as per NFPA 70E & CSA Z462
  - If Rated Voltage  $> 5kV$ :
    - Refer to required insulation levels for cabling (NEC 2020, 311.10)

Voltage		Insulation
< 5000		100 %
>5000	Ground fault on system < 1 min.	100 %
	1 min < t < 1 hour	133 %
	t > 1 hour	173%

# Pulsing

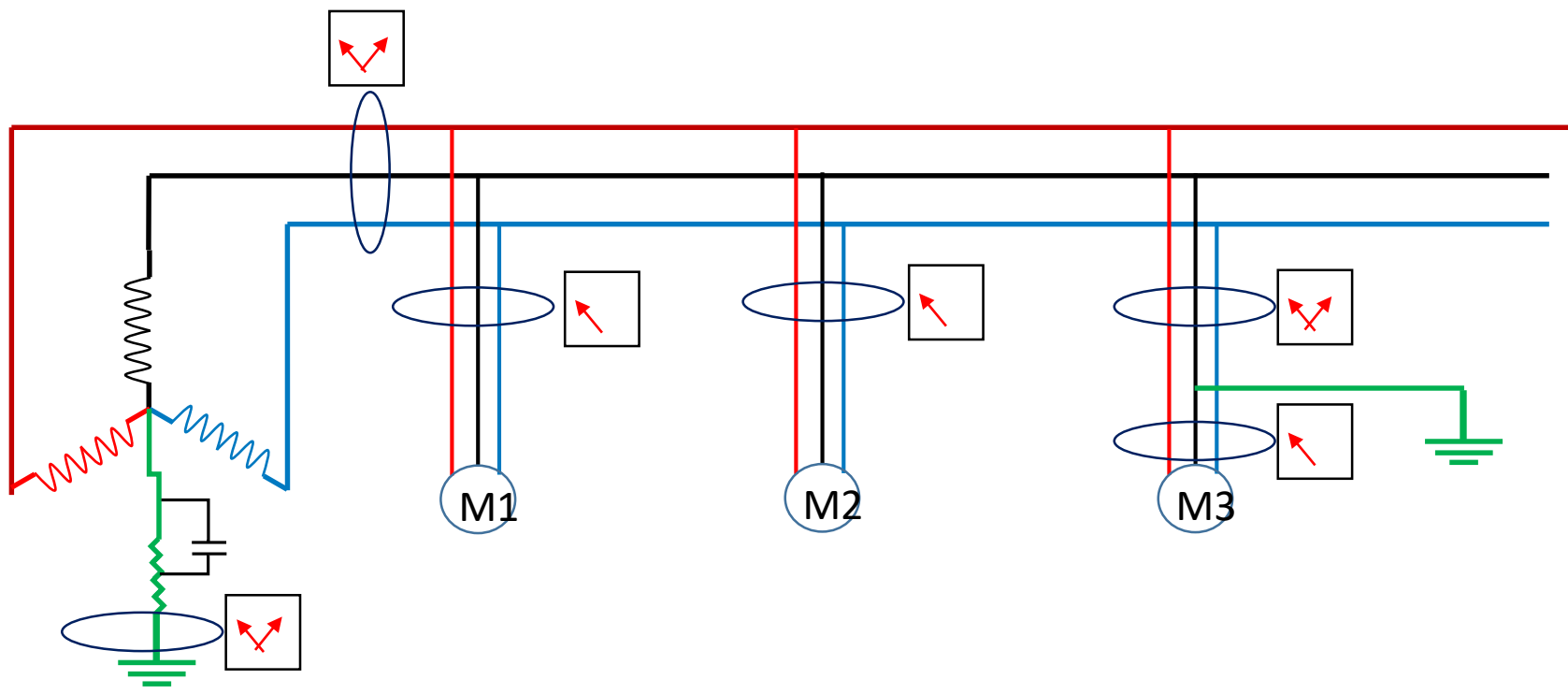



# Generator Applications

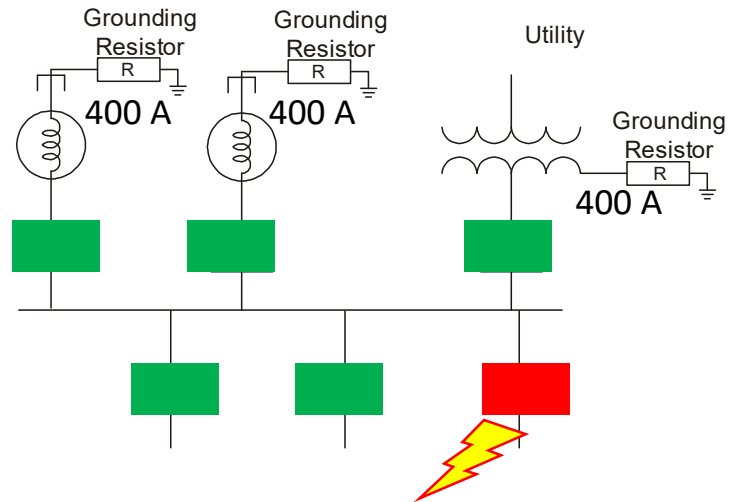

# Generator Applications

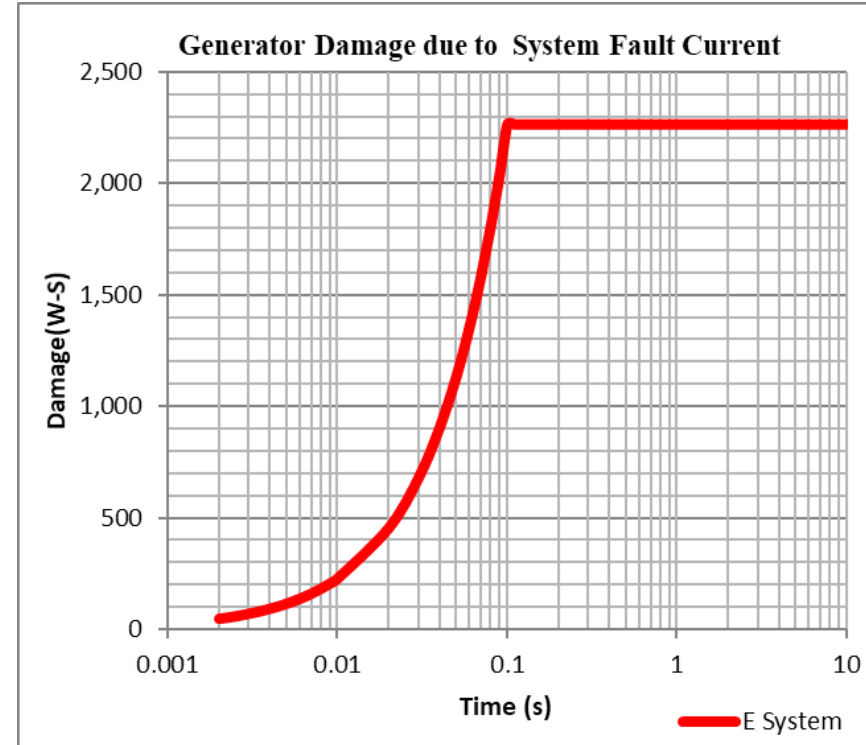
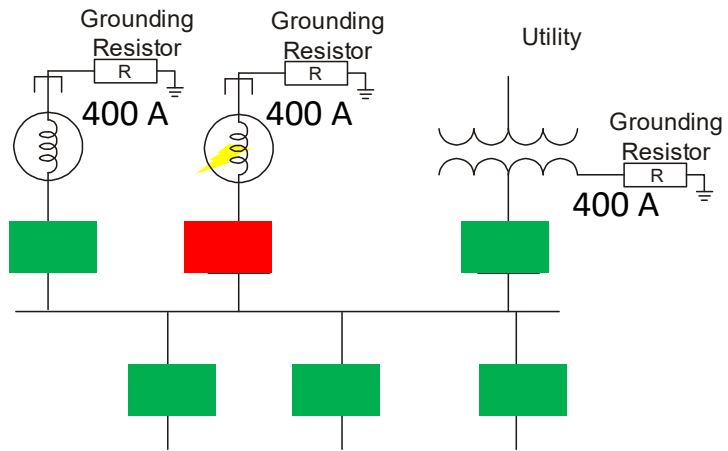

# Generator Applications

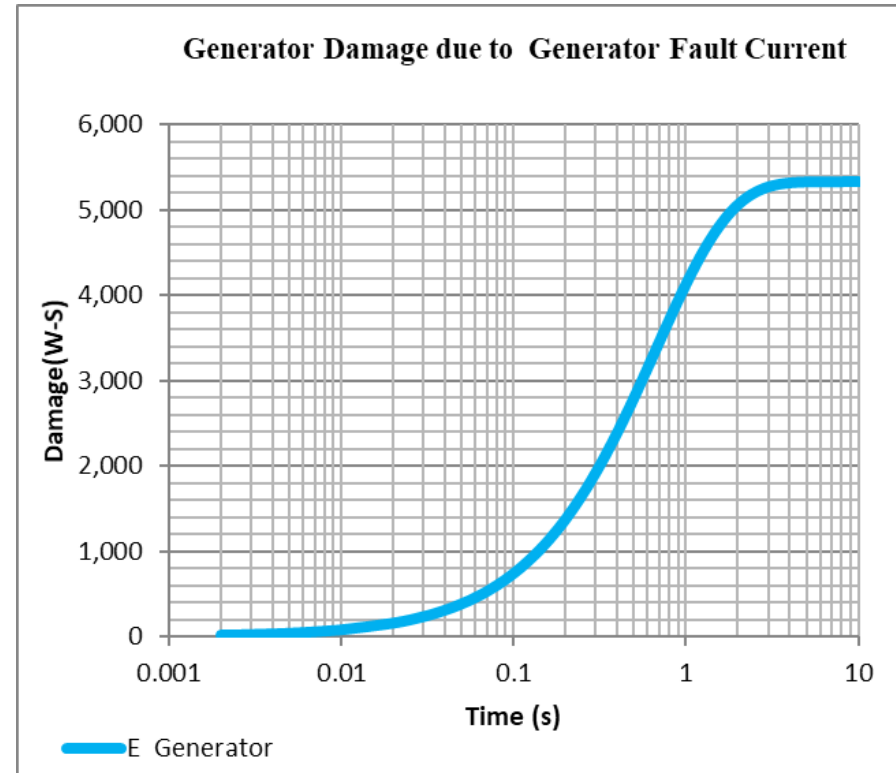
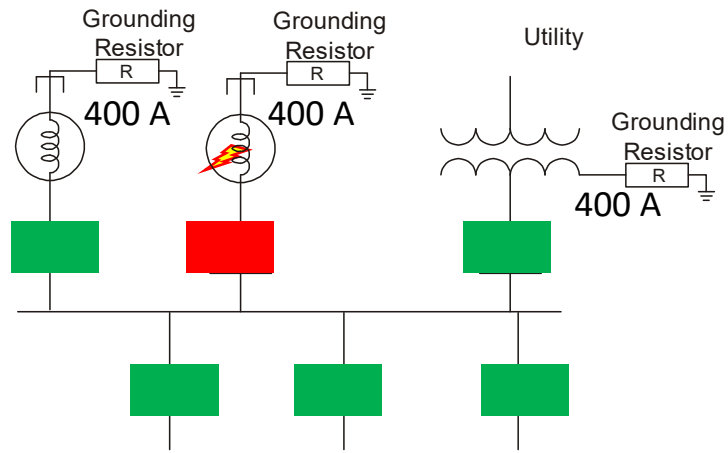

# Generator Applications

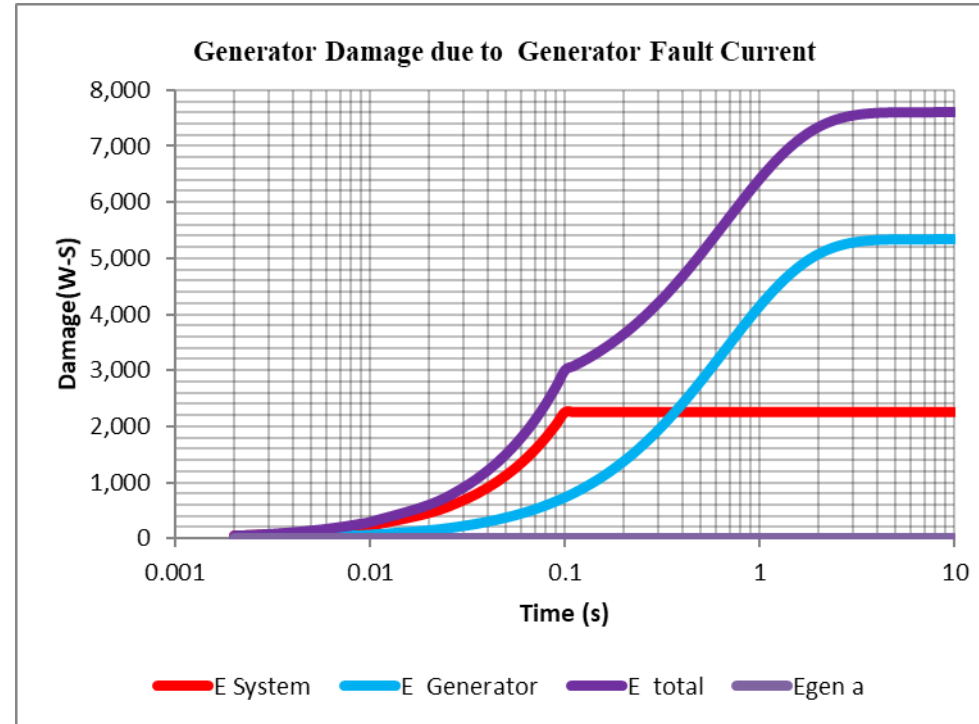
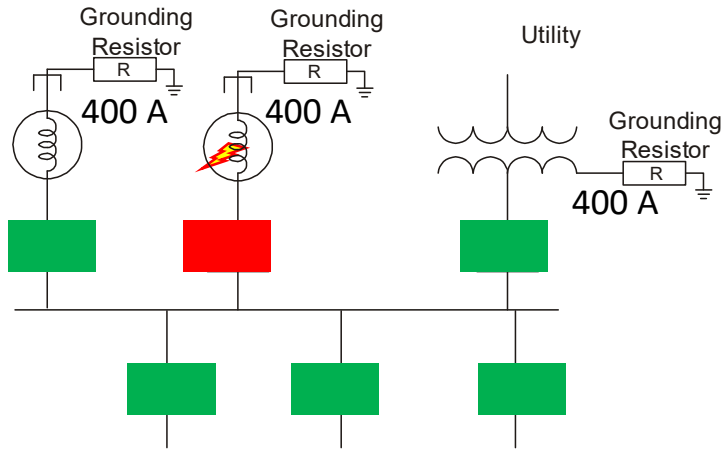

# Generator Applications

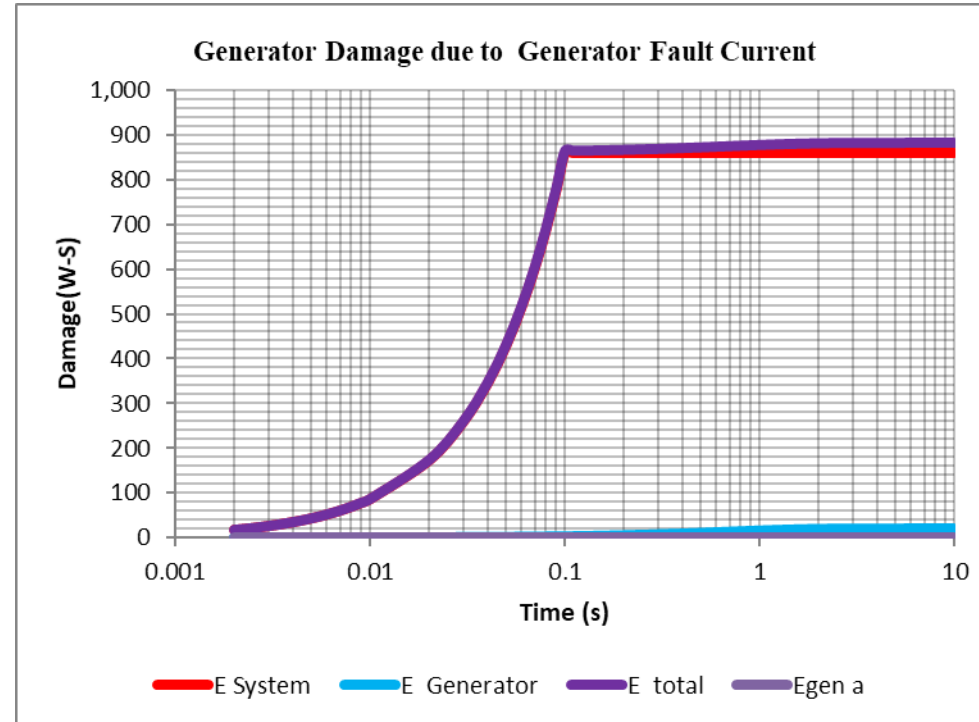
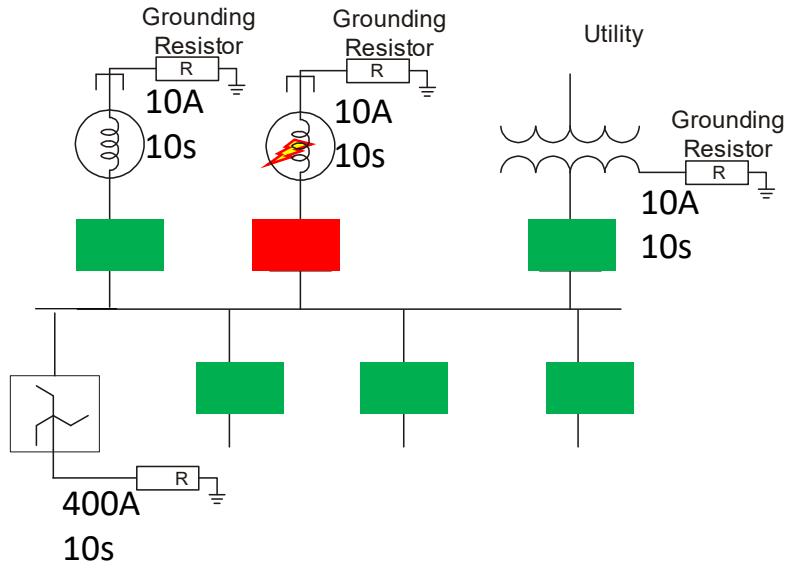

# Let's Compare....

	Ungrounded	Solidly Grounded	HRG
Process continuity under ground fault condition	✓	✗	✓
Control transient over-voltages	✗	✓	✓
Ability to locate ground fault	✗	✓	✓
1 → Process continuity of critical process with second ground fault	✗	✗	✗
2 → Arc Flash Mitigation for safety	✗	✗	✗

# Process Continuity of Critical Loads

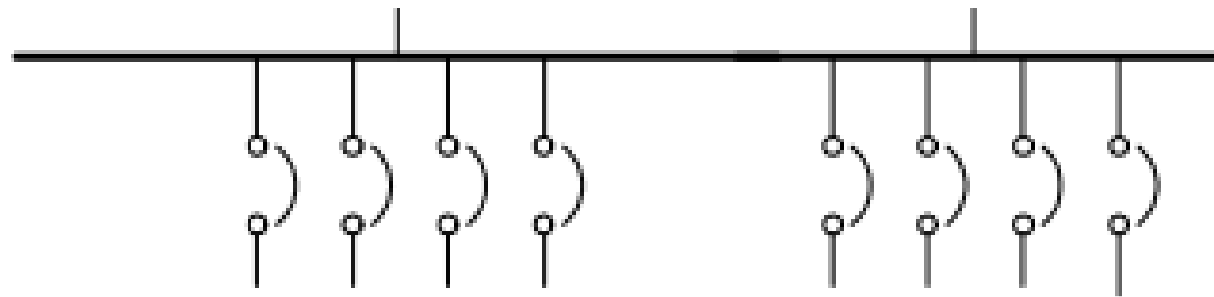

# Let's Compare....

	Ungrounded	Solidly Grounded	Resistive Grounding
Process continuity under ground fault condition	✓	✗	✓
Control transient over-voltages	✗	✓	✓
Ability to locate ground fault	✗	✓	✓
1 → Process continuity of critical process with second ground fault	✗	✗	✗
2 → Arc Flash Mitigation for safety	✗	✗	✗



# NFPA 70E



## 0.2.2

Design option decisions should facilitate the ability to eliminate hazards or reduce risk by doing the following:

- (1) Reducing the likelihood of exposure
- (2) Reducing the magnitude or severity of exposure
- (3) Enabling achievement of an electrically safe work condition

# NFPA 70E



## O.2.3 Incident Energy Reduction Methods.

The following methods have proved to be effective in reducing incident energy:

- (1) Zone-selective interlocking. This is a method that allows two or more circuit breakers to communicate with each other so that a short circuit or ground fault will be cleared by the breaker closest to the fault with no intentional delay. Clearing the fault in the shortest time aids in reducing the incident energy.
- (2) Differential relaying. The concept of this protection method is that current flowing into protected equipment must equal the current out of the equipment. If these two currents are not equal, a fault must exist within the equipment, and the relaying can be set to operate for a fast interruption. Differential relaying uses current transformers located on the line and load sides of the protected equipment and fast acting relay.
- (3) Energy-reducing maintenance switching with a local status indicator. An energy-reducing maintenance switch allows a worker to set a circuit breaker trip unit to operate faster while the worker is working within an arc flash boundary, as defined in **NFPA 70E**, and then to set the circuit breaker back to a normal setting after the work is complete.
- (4) Energy-reducing active arc flash mitigation system. This system can reduce the arcing duration by creating a low impedance current path, located within a controlled compartment, to cause the arcing fault to transfer to the new current path, while the upstream breaker clears the circuit. The system works without compromising existing selective coordination in the electrical distribution system.

# NFPA 70E

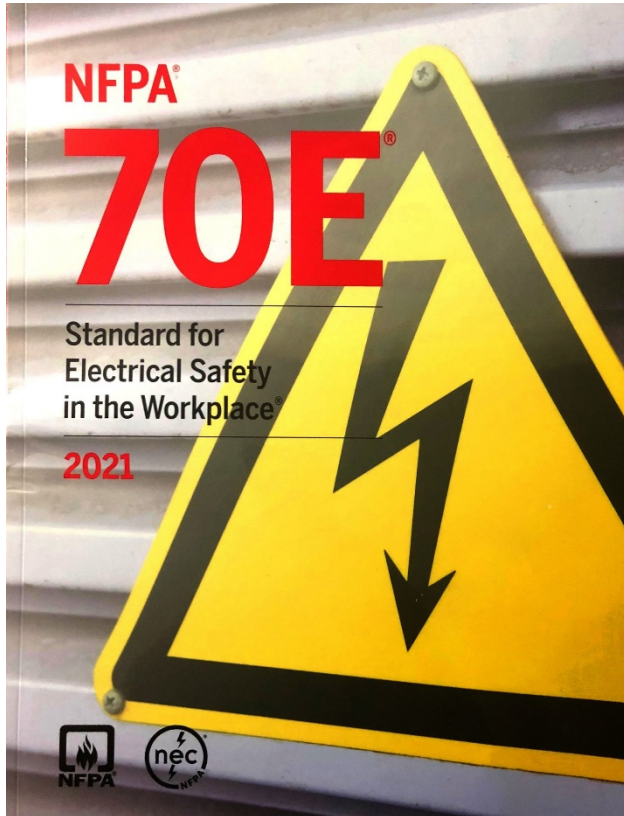

(5)Energy-reducing line side isolation. This is equipment that encloses the line side conductors and circuit parts and has been listed to provide both shock and arc flash protection from events on the line side of a circuit breaker or switch.

(6)Arc flash relay. An arc flash relay typically uses light sensors to detect the light produced by an arc flash event. Once a certain level of light is detected, the relay will issue a trip signal to an upstream overcurrent device.

(7)High-resistance grounding. A great majority of electrical faults are of the phase-to-ground type. High-resistance grounding will insert an impedance in the ground return path and will typically limit the fault current to 10 amperes and below (at 5 kV nominal or below), leaving insufficient fault energy and thereby helping reduce the arc flash hazard level. High-resistance grounding will not affect arc flash energy for line-to-line or line-to-line-to-line arcs.

(8)Current-limiting devices. Current limiting protective devices reduce incident energy by

**According to “Industrial Power System Grounding Design Handbook”, 95% of all electrical faults begin as single phase-to-ground faults.**

**With a low let through current, there is insufficient energy for the arc to re-strike, and as a result self-extinguishes.**

The energy  
d of the current-

e relay to switches  
mediately when  
s is especially  
of the three

# NFPA 70E

## Workplace Electrical Safety, Annex O:

O.2.2 Design option decisions should facilitate the ability to eliminate hazards or reduce risk by doing the following:

1. Reducing the likelihood of exposure, and
2. Reducing the magnitude of exposure
3. Enabling achievement of an electrically safe work condition

# SMART HRG

- **Selective Instantaneous Feeder Tripping**
- **Main-tie-Main Coordination**
- **Assisted Fault Location through feeder identification**
- **Reducing both the likelihood and **magnitude of exposure** for arc flash mitigation**
- **Time Selective Feeder Isolation**

# SMART HRG

## I-Gard DSP System

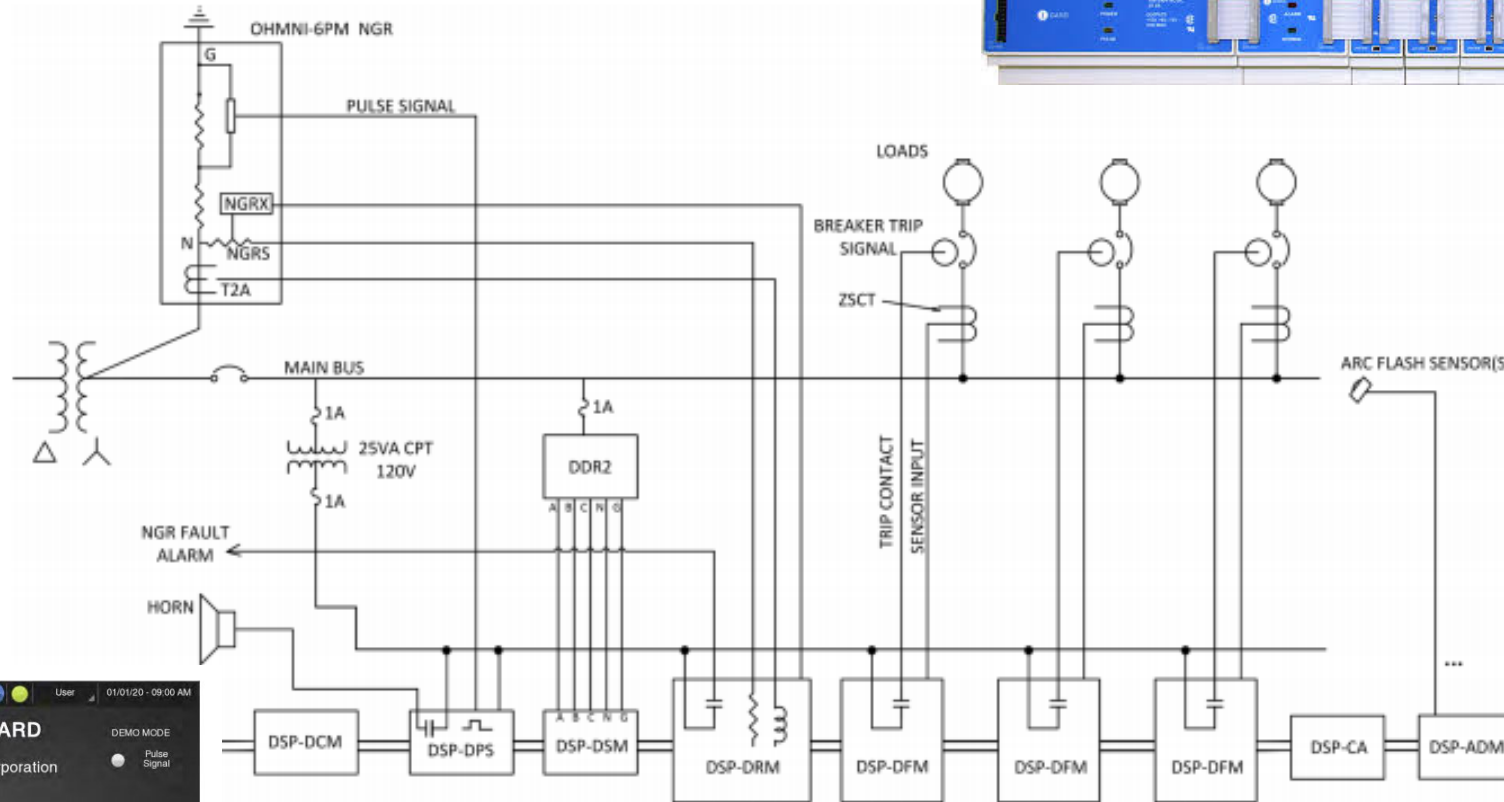
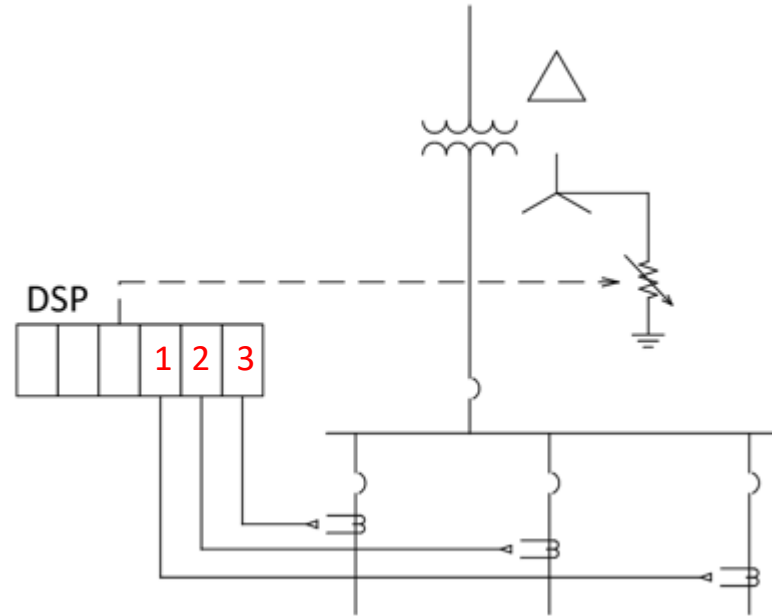

Figure 6: Home Screen



# Selective Instantaneous Feeder Tripping



# Let's Compare....

	Ungrounded	Solidly Grounded	Standard HRG	SMART HRG
Process continuity under ground fault condition	✓	✗	✓	✓
Control transient over-voltages	✗	✓	✓	✓
Ability to locate ground fault	✗	✓	✓	✓
Process continuity of critical process with second ground fault	✗	✗	✗	✓
Arc Flash Mitigation for safety	✗	✗	✗	



# Main-Tie-Main Coordination

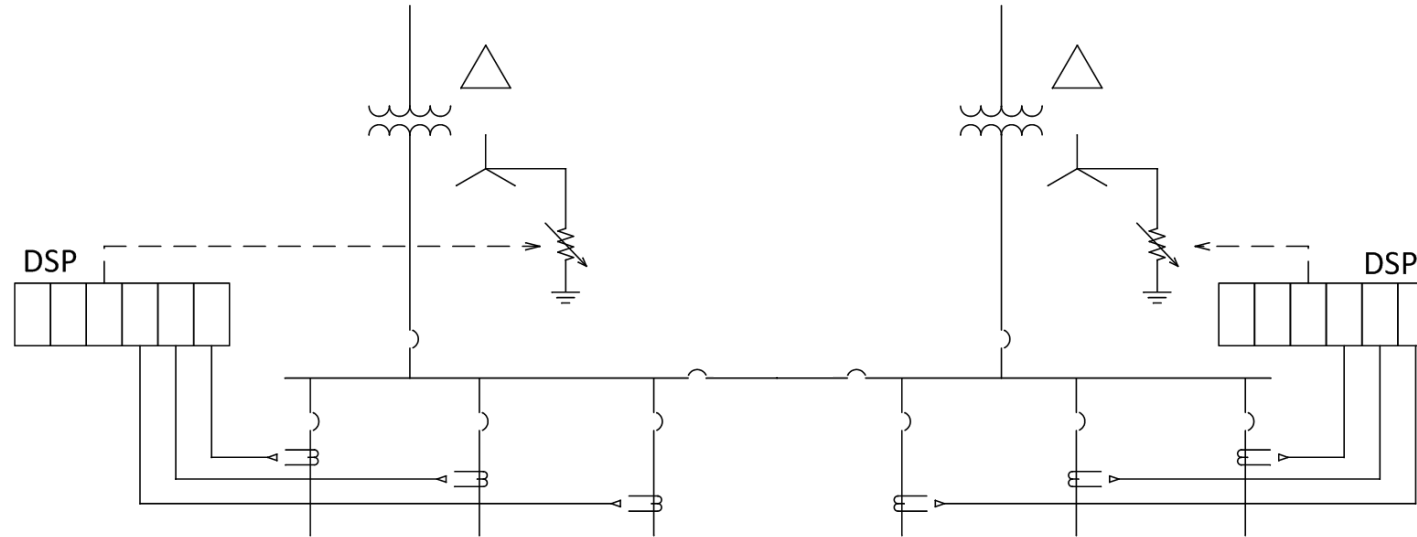

Main-Tie-Main DSP System

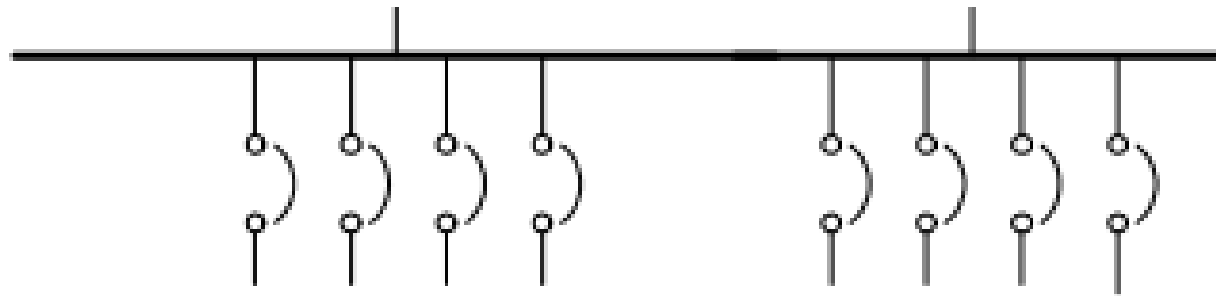

# Reducing the likelihood and magnitude

- Zone Selective Interlocking
- Differential relaying
- Energy-reducing maintenance switch
- Energy-reducing active arc flash mitigation system
- Arc flash relay
- High-resistance grounding
- Current-limiting devices

**(6) – “Arc Flash relay. An arc flash relay typically uses light sensors to detect the light produced by an arc flash event. Once a certain level of light is detected, the relay will issue a trip signal to an upstream overcurrent device.”**

(5)Energy-reducing line side isolation. This is equipment that encloses the line side conductors and circuit parts and has been listed to provide both shock and arc flash protection from events on the line side of a circuit breaker or switch.

(6)Arc flash relay. An arc flash relay typically uses light sensors to detect the light produced by an arc flash event. Once a certain level of light is detected, the relay will issue a trip signal to an upstream overcurrent device.

(7)High-resistance grounding. A great majority of electrical faults are of the phase-to-ground type. High-resistance grounding will insert an impedance in the ground return path and will typically limit the fault current to 10 amperes and below (at 5 kV nominal or below), leaving insufficient fault energy and thereby helping reduce the arc flash hazard level. High-resistance grounding will not affect arc flash energy for line-to-line or line-to-line-to-line arcs.

(8)Current-limiting devices. Current-limiting protective devices reduce incident energy by clearing the fault faster and by reducing the current seen at the arc source. The energy reduction becomes effective for current above the current-limiting threshold of the current-limiting fuse or current limiting circuit breaker.

(9)Shunt-trip. Adding a shunt-trip that is signaled to open from an open-fuse relay to switches 800 amperes and greater reduces incident energy by opening the switch immediately when the first fuse opens. The reduced clearing time reduces incident energy. This is especially helpful for arcing currents that are not within the current-limiting threshold of the three current-limiting fuses.

# Reducing the likelihood and magnitude

## 4.6 Intermediate incident energy (E)

Use Equation (3) to Equation (6) as follows and Table 3, Table 4, and Table 5 to determine the intermediate incident energy values:

$$E_{600} = \frac{12.552}{50} T \times 10^{\left( k1+k2 \lg G + \frac{k3 I_{sc,600}}{k4 I_w^2 + k5 I_w^4 + k6 I_w^6 + k7 I_w^8 + k8 I_w^{10} + k9 I_w^{12} + k10 I_w^{14}} + k11 \lg I_w + k12 \lg D + k13 \lg I_{sc,600} + \lg \frac{1}{CF} \right)} \quad (3)$$

$$E_{2700} = \frac{12.552}{50} T \times 10^{\left( k1+k2 \lg G + \frac{k3 I_{sc,2700}}{k4 I_w^2 + k5 I_w^4 + k6 I_w^6 + k7 I_w^8 + k8 I_w^{10} + k9 I_w^{12} + k10 I_w^{14}} + k11 \lg I_w + k12 \lg D + k13 \lg I_{sc,2700} + \lg \frac{1}{CF} \right)} \quad (4)$$

$$E_{14700} = \frac{12.552}{50} T \times 10^{\left( k1+k2 \lg G + \frac{k3 I_{sc,14700}}{k4 I_w^2 + k5 I_w^4 + k6 I_w^6 + k7 I_w^8 + k8 I_w^{10} + k9 I_w^{12} + k10 I_w^{14}} + k11 \lg I_w + k12 \lg D + k13 \lg I_{sc,14700} + \lg \frac{1}{CF} \right)} \quad (5)$$

$$E_{\leq 600} = \frac{12.552}{50} T \times 10^{\left( k1+k2 \lg G + \frac{k3 I_{sc,600}}{k4 I_w^2 + k5 I_w^4 + k6 I_w^6 + k7 I_w^8 + k8 I_w^{10} + k9 I_w^{12} + k10 I_w^{14}} + k11 \lg I_w + k12 \lg D + k13 \lg I_{sc,600} + \lg \frac{1}{CF} \right)} \quad (6)$$

**Reduce the duration of the arc fault**



**Arc Flash Relays!**

# NFPA 70E

## Workplace Electrical Safety, Annex O:

O.2.2 Design option decisions should facilitate the ability to eliminate hazards or reduce risk by doing the following:

1. Reducing the likelihood of exposure, and
2. Reducing the magnitude of exposure
3. Enabling achievement of an electrically safe work condition

# Let's Compare....

	Ungrounded	Solidly Grounded	Standard HRG	SMART HRG
Process continuity under ground fault condition	✓	✗	✓	✓
Control transient over-voltages	✗	✓	✓	✓
Ability to locate ground fault	✗	✓	✓	✓
Process continuity of critical process with second ground fault	✗	✗	✗	✓
Arc Flash Mitigation for safety	✗	✗	✗	✓

# Time Selective Feeder Isolation

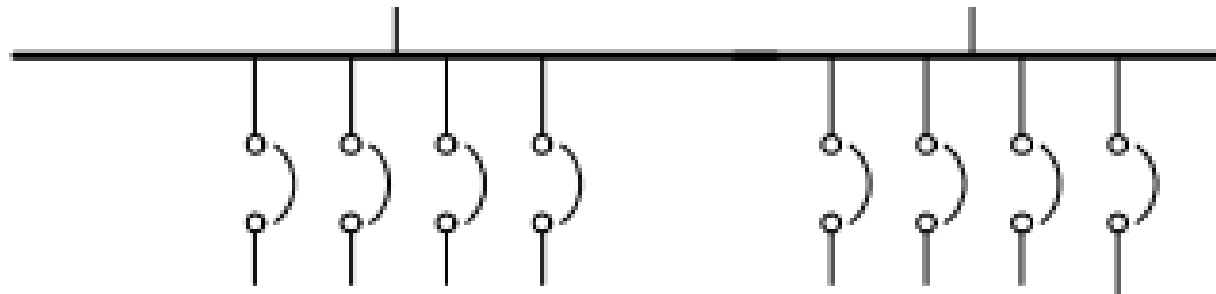

# Standard HRG vs Smart HRG

How to Specify

Smart HRG provides everything that Standard HRG has, including:

- Faulted feeder indication and monitoring
- Selective feeder tripping (0-15)
- Arc flash mitigation technique as per NFPA 70E
- Accommodates Main-Tie-Main applications
- Modbus TCP/IP for communications
- Provides a touch screen interface



Thank you

Questions?

# Our Newest DSP Display Module – DSP-TDM

The TDM assists in locating ground faults via a display indication of:

1. Alarm of first/second ground fault
2. Faulted phase
3. Individual feeder ID
4. Magnitude of ground fault for:
  - Overall system
  - Individual feeder locations
5. Feeder assigned priority levels
6. Status of NGR
7. Loss of phase voltages
8. BUS fault



Figure 6: Home Screen

# DSP-TDM



Figure 7: Alarm Screen



Figure 27: Alarm Screen

# DSP-TDM



Figure 8: Settings Page

#	Name	Igf (%)	Igf (A)	Priority	Delay	Status
3	MCC - East Plant	1%	0.1A	3	--	OK
4	CPB - 5A	80%	0.0A	4	--	Fault
5	MCC - 2B	1%	0.1A	5	--	OK
6	PP - 2C	0%	0.0A	6	--	Trip
7	DP - 3BB	1%	0.1A	7	--	OK
8	PP - 1A	1%	0.1A	8	--	Test
9	PP - 1B	--	--	--	--	NOT DETECTED
10	PP - 1C	1%	0.1A	10	--	OK

Figure 23: Feeder Current  $I_{gf}$

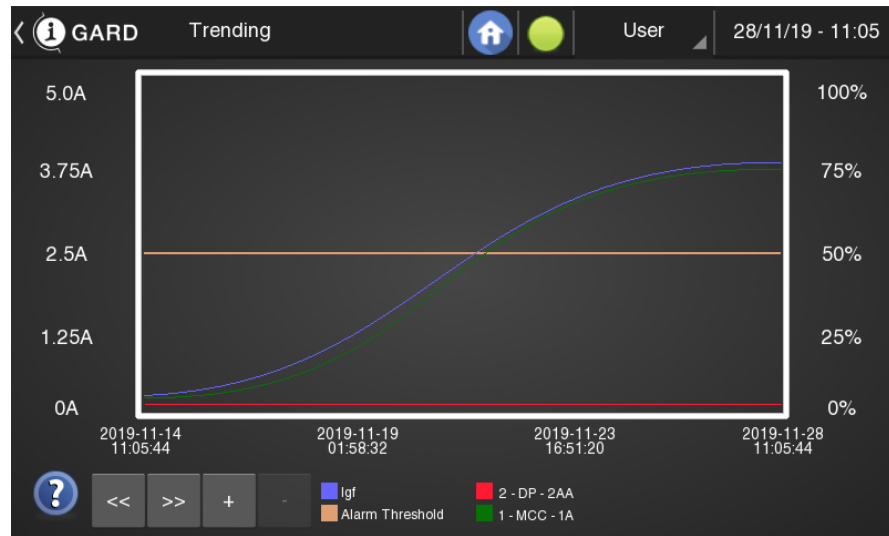

Figure 31: Trending page



Figure 30: Momentary Feeder Fault Example